

# AWWA C508 SWING CHECK VALVE

## Model 7700

ANSI 125 Body • Bolted Cap  
Bronze Seat Ring • Buna Seal

# UNITED



Series 7700 (without lever or weight)  
Series 7700-LW (with lever & weight)  
Series 7700-LS (with lever & spring)

### MATERIAL LIST

ITEM NO.	DESCRIPTION	MATERIAL
1	Body	ASTM A126, Class B
2	Stud	AISI 304
3	Nut	AISI 304
4	Washer	AISI 304
5	Hanger	ASTM A126, Class B
6	Clapper and Seal	ASTM A126, Class B NBR
7	Seat Ring	ASTM B62 C83600
8	Spring Pin	AISI 304
9	Hanger Shaft	AISI 304
10	Gasket	NBR
11	Cover	ASTM A126, Class B
12	Bolt	AISI 304
13	Shaft Nut	AISI 304
14	Shaft Washer	AISI 304
15	Lever	AISI 1020
16	Weight	ASTM A126, Class B
17	Washer	PTFE
18	Set Screw	Carbon Steel
19	Packing Nut	Brass

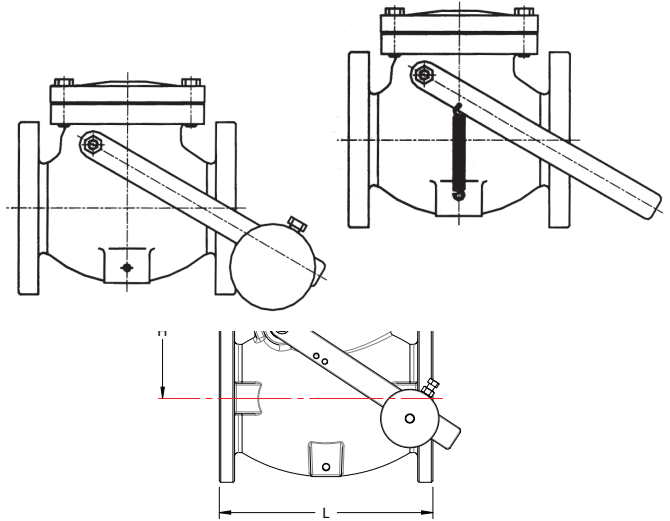

### DIMENSIONAL DATA

Nominal Size	Part No.	L	H
2"	7700-F-120-*	8	4-3/4
2-1/2"	7700-F-125-*	8-1/2	5-5/16
3"	7700-F-130-*	9-1/2	5-1/2
4"	7700-F-140-*	11-1/2	6-5/8
5"	7700-F-150-*	13	7-3/18
6"	7700-F-160-*	14	8-15/32
8"	7700-F-180-*	19-1/2	10-1/2
10"	7700-F-200-*	24-1/2	12
12"	7700-F-220-*	27.5	13-1/2
14"	7700-F-240-*	31	17-3/4
16"	7700-F-260-*	36	20-1/2
18"	7700-F-280-*	38	21-5/8
20"	7700-F-300-*	40	23-1/4
24"	7700-F-340-*	48	26-3/4

\*Indicate (LW - with lever & weight,

LS - with lever & spring)

Dimensions in inches

Note: Design and materials subject to change without notice.

#### NOTES:

1. Flange drilling to ANSI 125/150. Metric PN10/PN16 drilling is available upon request.
2. End to End Dimensions (Laying Length) to AWWA C-508 Standard for Full Waterway Swing Check Valves
3. Maximum working pressure-temperature: 200 psi @ -29°C to 64°C (-20°F to 150F).
4. Suitable for Water / Sludge / Sewage service
5. Fusion Bonded Epoxy Coated Interior and Exterior to AWWA C550. Powder Certified to NSF-61
6. Installed with standard flange accessories (AWWA C110).
7. Meets all requirements of MSS SP-71.



**WARNING:** This product can expose you to chemicals including lead, which is known to the State of California to cause cancer and birth defects or other reproductive harm. For more information go to [www.P65Warnings.ca.gov](http://www.P65Warnings.ca.gov).

**UNITED** Water Products

**United Water Products**  
5355 Ramona Blvd., Jacksonville, FL 32205  
TEL. 877-766-4459 FAX: 877-766-4458  
Website: [www.unitedwaterproducts.com](http://www.unitedwaterproducts.com)